



# JCS4N70C

## 主要参数MAIN CHARACTERISTICS

$I_D$	4.0 A
$V_{DSS}$	700 V
$R_{dson-max}$ ( $V_{gs}=10V$ )	2.8 $\Omega$
$Q_g-Typ$	16nC

### 用途

- 高频开关电源
- 电子镇流器
- LED 电源

### 产品特性

- 低栅极电荷
- 低  $C_{rss}$  (典型值 5.78pF)
- 开关速度快
- 产品全部经过雪崩测试
- 高抗  $dv/dt$  能力
- RoHS 产品

### APPLICATIONS

- High efficiency switch mode power supplies
- Electronic lamp ballasts based on half bridge
- LED power supplies

### FEATURES

- Low gate charge
- Low  $C_{rss}$  (typical 5.78pF)
- Fast switching
- 100% avalanche tested
- Improved  $dv/dt$  capability
- RoHS product

## 封装 Package

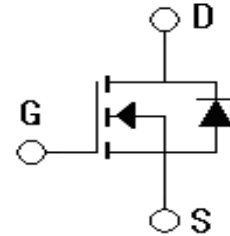



## 订货信息 ORDER MESSAGE

订货型号 Order codes				印记 Marking	封装 Package
有卤-条管 Halogen-Tube	无卤-条管 Halogen-Free-Tube	有卤-编带 Halogen-Reel	无卤-编带 Halogen-Free-Reel		
N/A	JCS4N70VC-V-BR	N/A	N/A	JCS4N70V	IPAK
N/A	JCS4N70VC-VQ-BR	N/A	N/A	JCS4N70V	TO-251N-S2
N/A	JCS4N70RC-R-BR	N/A	JCS4N70RC-R-AR	JCS4N70R	DPAK
JCS4N70MFC-MF-B	JCS4N70MFC-MF-BR	N/A	N/A	JCS4N70MF	TO-126F
JCS4N70CC-C-B	JCS4N70CC-C-BR	N/A	N/A	JCS4N70C	TO-220C
JCS4N70FC-F-B	JCS4N70FC-F-BR	N/A	N/A	JCS4N70F	TO-220MF
JCS4N70FC-F1-B	JCS4N70FC-F1-BR	N/A	N/A	JCS4N70F	TO-220MF-K1
JCS4N70FC-F2-B	JCS4N70FC-F2-BR	N/A	N/A	JCS4N70F	TO-220MF-K2
JCS4N70BC-B-B	JCS4N70BC-B-BR	N/A	N/A	JCS4N70B	TO-262
JCS4N70SC-S-B	JCS4N70SC-S-BR	JCS4N70SC-S-A	JCS4N70SC-S-AR	JCS4N70S	TO-263





## 绝对最大额定值ABSOLUTE RATINGS(Tc=25℃)

项 目 Parameter	符 号 Symbol	数 值 Value				单 位 Unit
		JCS4N70 MFC	JCS4N70 VC/RC	JCS4N70 SC/BC/CC	JCS4N70 FC	
最高漏极-源极直流电压 Drain-Source Voltage	V <sub>DSS</sub>	700				V
连续漏极电流 Drain Current -continuous	I <sub>D</sub> T=25℃ T=100℃	4.0		4.0*		A
		2.5		2.5*		A
最大脉冲漏极电流 (注1) Drain Current - pulse (note 1)	I <sub>DM</sub>	16		16*		A
最高栅源电压 Gate-Source Voltage	V <sub>GSS</sub>	±30				V
单脉冲雪崩能量 (注2) Single Pulsed Avalanche Energy(note 2)	E <sub>AS</sub>	265				mJ
雪崩电流 (注1) Avalanche Current (note 1)	I <sub>AR</sub>	4.0				A
重复雪崩能量 (注1) Repetitive Avalanche Current (note 1)	E <sub>AR</sub>	11.0				mJ
二极管反向恢复最大电压变化速 率 (注3) Peak Diode Recovery dv/dt (note 3)	dv/dt	5.0				V/ns
耗散功率 Power Dissipation	P <sub>D</sub> T <sub>C</sub> =25℃ -Derate above25℃	26	51	100	33	W
		0.21	0.39	0.80	0.26	W/℃
最高结温及存储温度 Operating and Storage Temperature Range	T <sub>J</sub> , T <sub>STG</sub>	-55~+150				℃
引线最高焊接温度 Maximum Lead Temperature for Soldering Purposes	T <sub>L</sub>	300				℃

\*漏极电流由最高结温限制

\*Drain current limited by maximum junction temperature





## 电特性 ELECTRICAL CHARACTERISTICS

项目 Parameter	符号 Symbol	测试条件 Tests conditions	最小 Min	典型 Typ	最大 Max	单位 Units
<b>关态特性 Off –Characteristics</b>						
漏-源击穿电压 Drain-Source Voltage	$BV_{DSS}$	$I_D=250\mu A, V_{GS}=0V$	700	-	-	V
击穿电压温度特性 Breakdown Voltage Temperature Coefficient	$\Delta BV_{DSS}/\Delta T_J$	$I_D=250\mu A$ , referenced to 25°C	-	0.66	-	V/°C
零栅压下漏极漏电流 Zero Gate Voltage Drain Current	$I_{DSS}$	$V_{DS}=700V, V_{GS}=0V, T_C=25^\circ C$	-	-	1	$\mu A$
		$V_{DS}=560V, T_C=125^\circ C$	-	-	100	$\mu A$
正向栅极体漏电流 Gate-body leakage current, forward	$I_{GSSF}$	$V_{DS}=0V, V_{GS}=30V$	-	-	100	nA
反向栅极体漏电流 Gate-body leakage current, reverse	$I_{GSSR}$	$V_{DS}=0V, V_{GS}=-30V$	-	-	-100	nA
<b>通态特性 On-Characteristics</b>						
阈值电压 Gate Threshold Voltage	$V_{GS(th)}$	$V_{DS} = V_{GS}, I_D=250\mu A$	2.0	-	4.0	V
静态导通电阻 Static Drain-Source On-Resistance	$R_{DS(ON)}$	$V_{GS} = 10V, I_D=2A$	-	2.6	2.8	$\Omega$
正向跨导 Forward Transconductance	$g_{fs}$	$V_{DS} = 40V, I_D=2A$ (note 4)	-	3.6	-	S
<b>动态特性 Dynamic Characteristics</b>						
输入电容 Input capacitance	$C_{iss}$	$V_{DS}=25V,$ $V_{GS}=0V,$ $f=1.0MHz$	-	790	-	pF
输出电容 Output capacitance	$C_{oss}$		-	67	-	pF
反向传输电容 Reverse transfer capacitance	$C_{rss}$		-	5.78	-	pF





## 电特性 ELECTRICAL CHARACTERISTICS

开关特性 Switching Characteristics						
延迟时间 Turn-On delay time	$t_d(\text{on})$	$V_{DD}=350V, I_D=4A, R_G=25\Omega$ (note 4, 5)	-	30	50	ns
上升时间 Turn-On rise time	$t_r$		-	65	110	ns
延迟时间 Turn-Off delay time	$t_d(\text{off})$		-	50	130	ns
下降时间 Turn-Off Fall time	$t_f$		-	45	90	ns
栅极电荷总量 Total Gate Charge	$Q_g$	$V_{DS}=560V,$ $I_D=4A$ $V_{GS}=10V$ (note 4, 5)	-	16	20	nC
栅-源电荷 Gate-Source charge	$Q_{gs}$		-	2.0	-	nC
栅-漏电荷 Gate-Drain charge	$Q_{gd}$		-	7.0	-	nC
漏-源二极管特性及最大额定值 Drain-Source Diode Characteristics and Maximum Ratings						
正向最大连续电流 Maximum Continuous Drain-Source Diode Forward Current		$I_S$	-	-	4	A
正向最大脉冲电流 Maximum Pulsed Drain-Source Diode Forward Current		$I_{SM}$	-	-	16	A
正向压降 Drain-Source Diode Forward Voltage	$V_{SD}$	$V_{GS}=0V, I_S=4.0A$	-	-	1.4	V
反向恢复时间 Reverse recovery time	$t_{rr}$	$V_{GS}=0V, I_S=4.0A$ $di_F/dt=100A/\mu s$ (note 4)	-	340	-	ns
反向恢复电荷 Reverse recovery charge	$Q_{rr}$		-	2.65	-	$\mu C$

## 热特性 THERMAL CHARACTERISTIC

项 目 Parameter	符 号 Symbol	最大 Max				单 位 Unit
		JCS4N70 MFC	JCS4N70 VC/RC	JCS4N70 SC/BC/CC	JCS4N70 FC	
结到管壳的热阻 Thermal Resistance, Junction to Case	$R_{th(j-c)}$	4.8	2.50	1.25	3.79	$^{\circ}C/W$
结到环境的热阻 Thermal Resistance, Junction to Ambient	$R_{th(j-A)}$	110	83	62.5	62.5	$^{\circ}C/W$

注释:

- 1: 脉冲宽度由最高结温限制
- 2:  $L=31mH, I_{AS}=4A, V_{DD}=50V, R_G=25\Omega$ , 起始结温  $T_J=25^{\circ}C$
- 3:  $I_{SD} \leq 4A, di/dt \leq 200A/\mu s, V_{DD} \leq BV_{DSS}$ , 起始结温  $T_J=25^{\circ}C$
- 4: 脉冲测试: 脉冲宽度 $\leq 300\mu s$ , 占空比 $\leq 2\%$
- 5: 基本与工作温度无关

Notes:

- 1: Pulse width limited by maximum junction temperature
- 2:  $L=31mH, I_{AS}=4A, V_{DD}=50V, R_G=25\Omega$ , Starting  $T_J=25^{\circ}C$
- 3:  $I_{SD} \leq 4A, di/dt \leq 200A/\mu s, V_{DD} \leq BV_{DSS}$ , Starting  $T_J=25^{\circ}C$
- 4: Pulse Test: Pulse Width  $\leq 300\mu s$ , Duty Cycles  $\leq 2\%$
- 5: Essentially independent of operating temperature





特征曲线ELECTRICAL CHARACTERISTICS (curves)

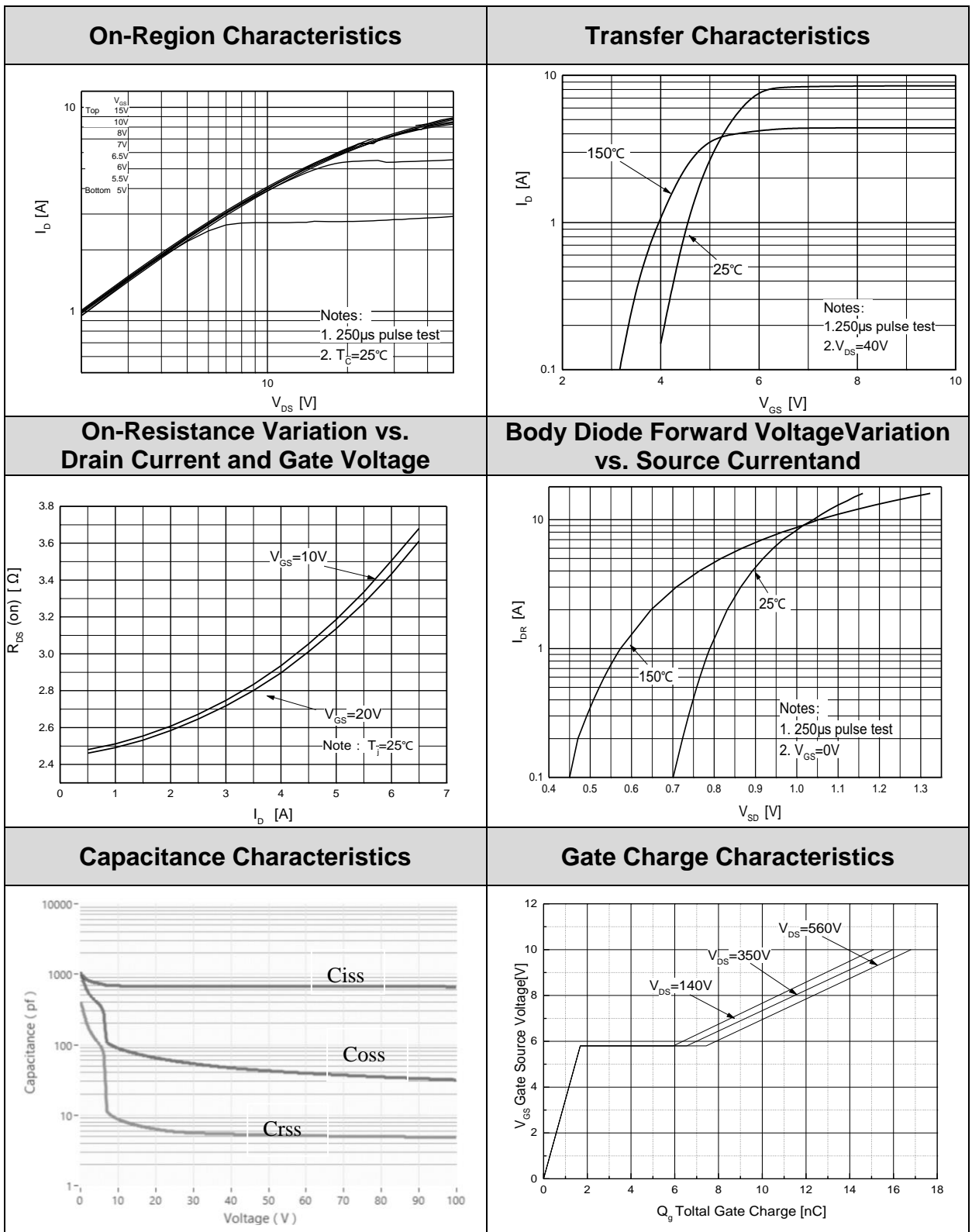



特征曲线ELECTRICAL CHARACTERISTICS (curves)

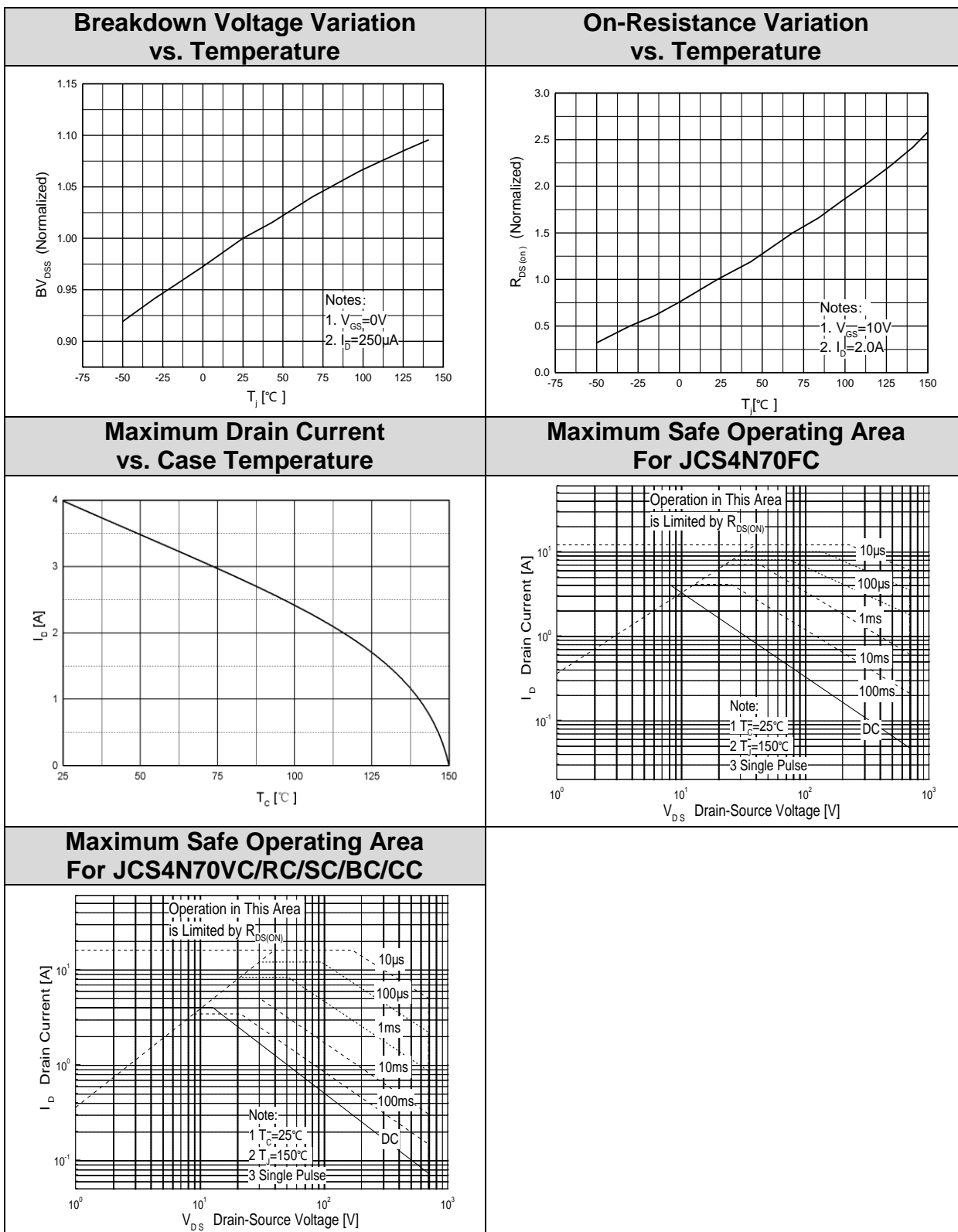



Transient Thermal Response Curve For JCS4N70VC/RC

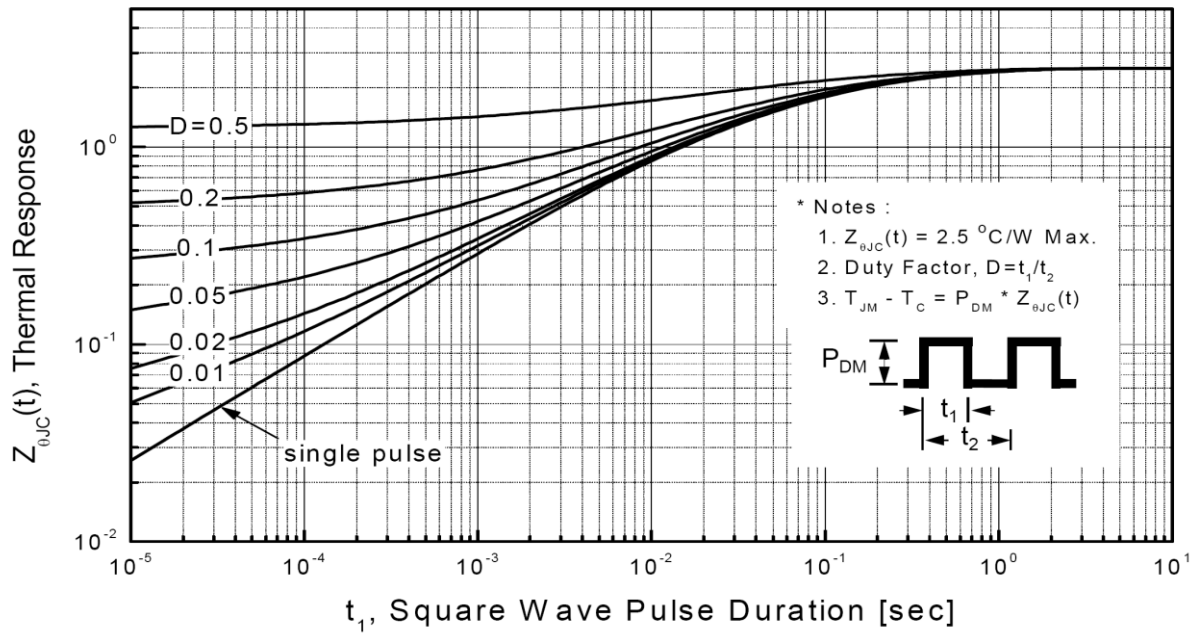

Transient Thermal Response Curve For JCS4N70SC/BC/CC

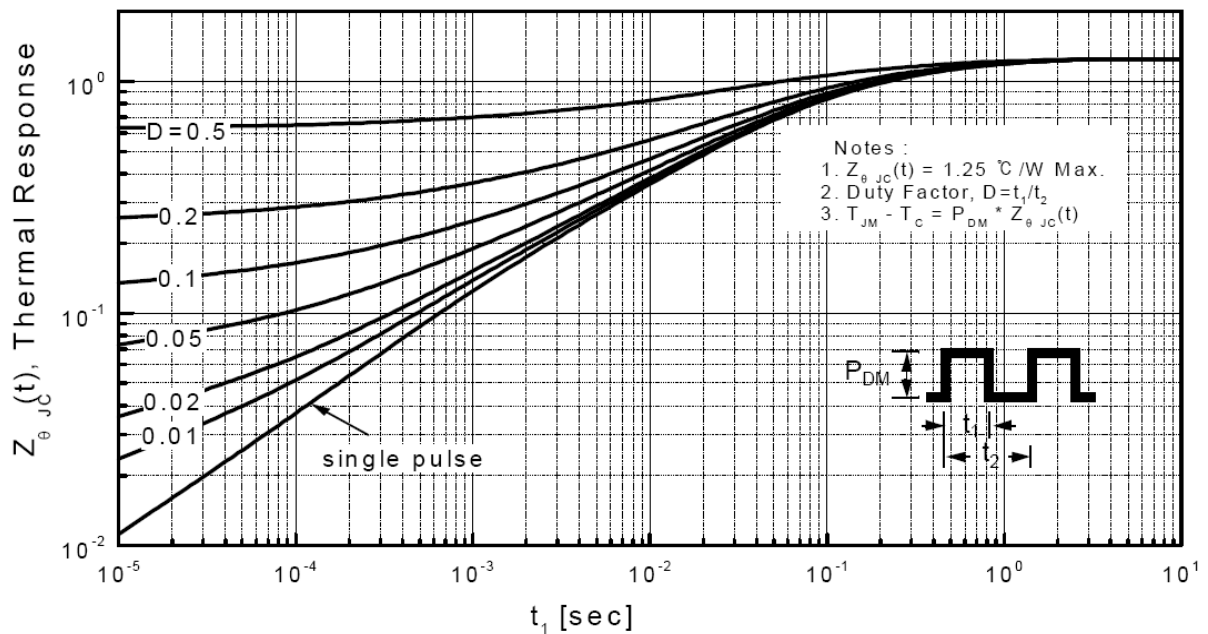





Transient Thermal Response Curve For JCS4N70FC

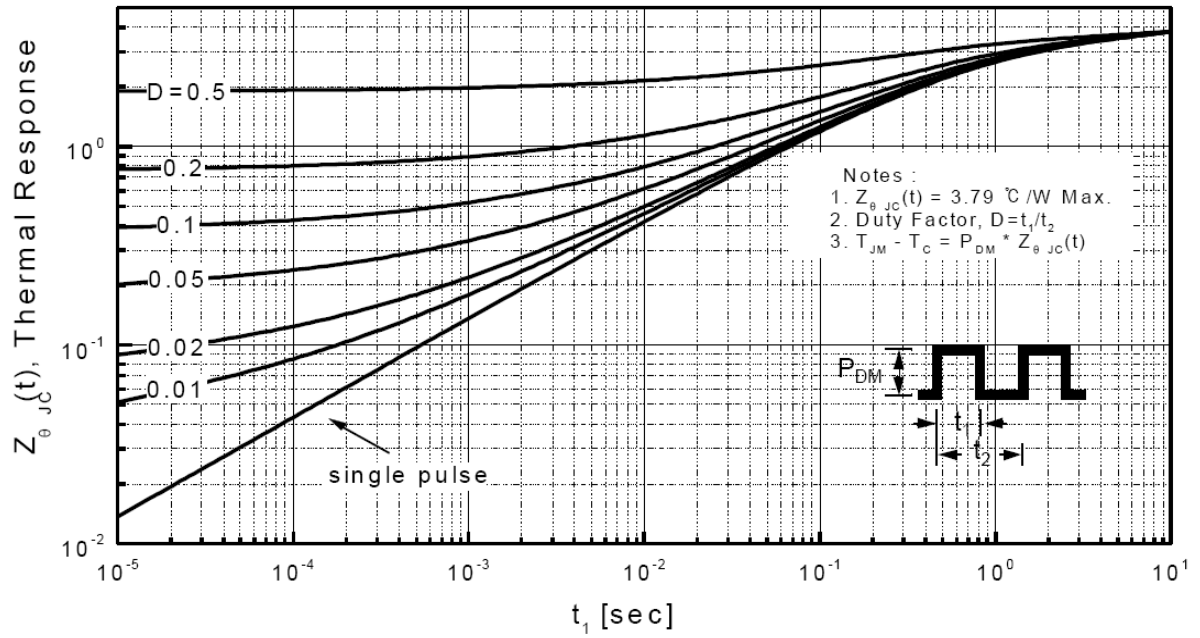



TO-126F

单位 Unit: mm

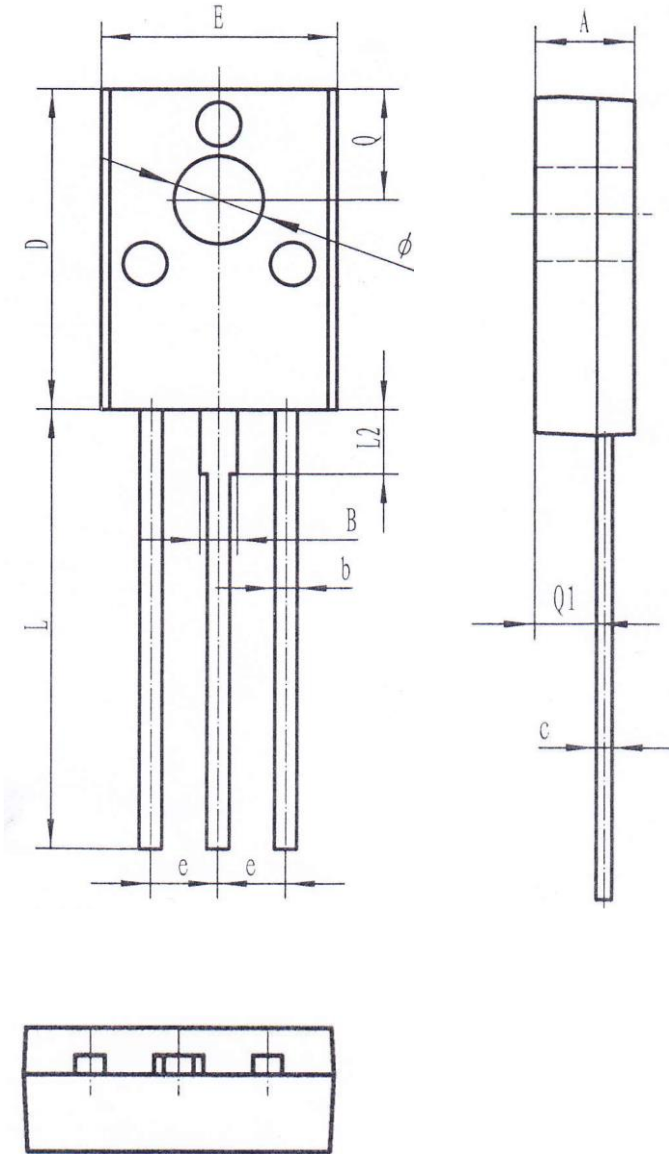

符号 symbol	MIN	MAX
A	3.10	3.30
B	1.22	1.47
b	0.60	0.90
c	0.45	0.70
D	10.50	11.20
E	7.50	8.50
e	2.29 TYP	
L	15.00	16.00
L2	2.10	2.30
Q	3.60	4.00
Q1	1.80	2.20
P	2.95	3.15



IPAK

单位 Unit: mm

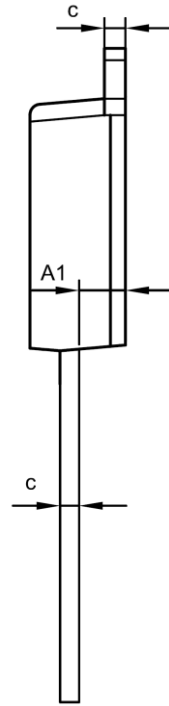
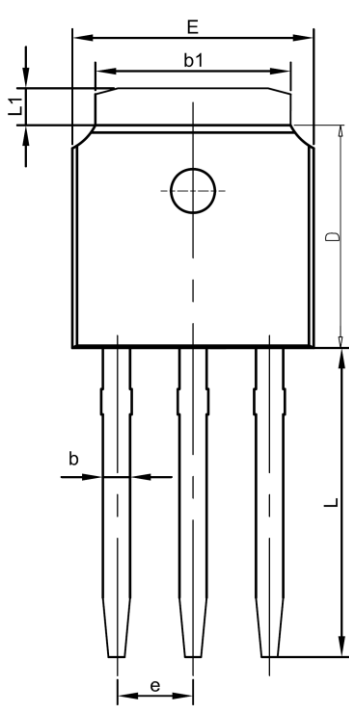

SYMBOL	MM	
	MIN	MAX
A	2.1	2.5
A1	0.87	1.27
b	0.63	0.93
b1	5.13	5.53
c	0.40	0.60
D	5.80	6.40
E	6.30	6.90
L	9.10	9.70
e	2.286BSC	
L1	0.82	1.22

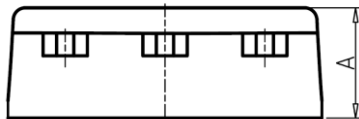



## TO-251N-S2

单位 Unit: mm

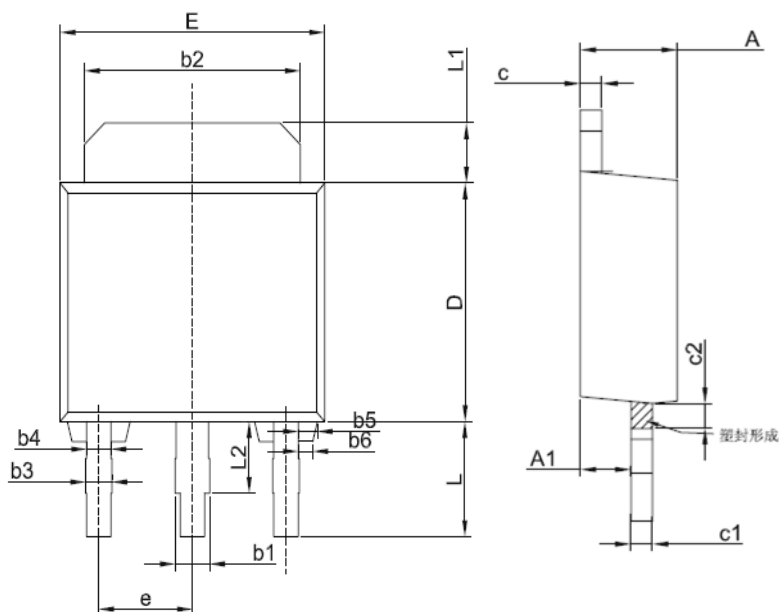

SYMBOL	MM	
	MIN	MAX
A	2.050	2.550
A1	1.050	1.350
b1	0.680	0.920
b2	5.150	5.450
b3	0.530	0.770
b4	0.480	0.720
b5	0.280	0.520
b6	0.180	0.420
c	0.400	0.600
c1	0.400	0.600
c2	0.180	0.420
D	5.350	5.850
E	6.350	6.850
e	2.3 (TYP)	
L	2.550	3.050
L1	1.4	1.8
L2	1.25	1.55



外形尺寸 PACKAGE MECHANICAL DATA

**DPAK**

单位 Unit: mm

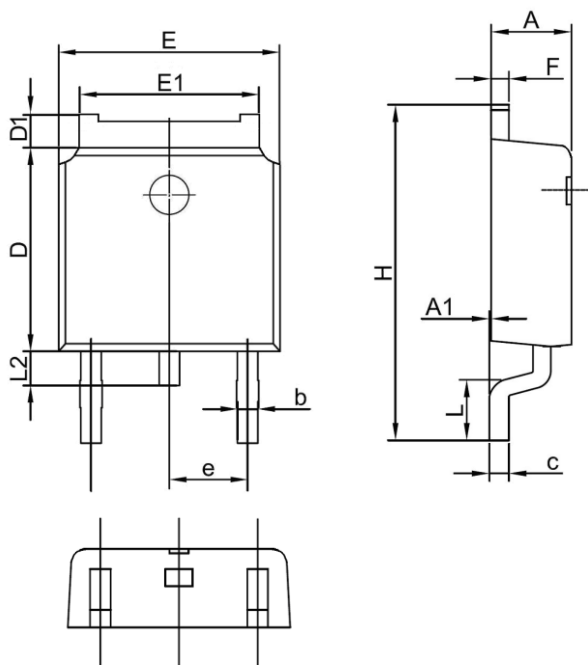

符号 symbol	MIN	MAX
A	2.2	2.4
A1	0.0	0.2
b	0.7	0.9
c	0.45	0.55
D	6.0	6.3
D1	0.8	1.2
E	6.5	6.8
E1	5.2	5.5
e	2.28TYP	
F	0.45	0.55
H	9.65	10.45
L	1.4	1.7
L2	0.6	1.0

编带 REEL

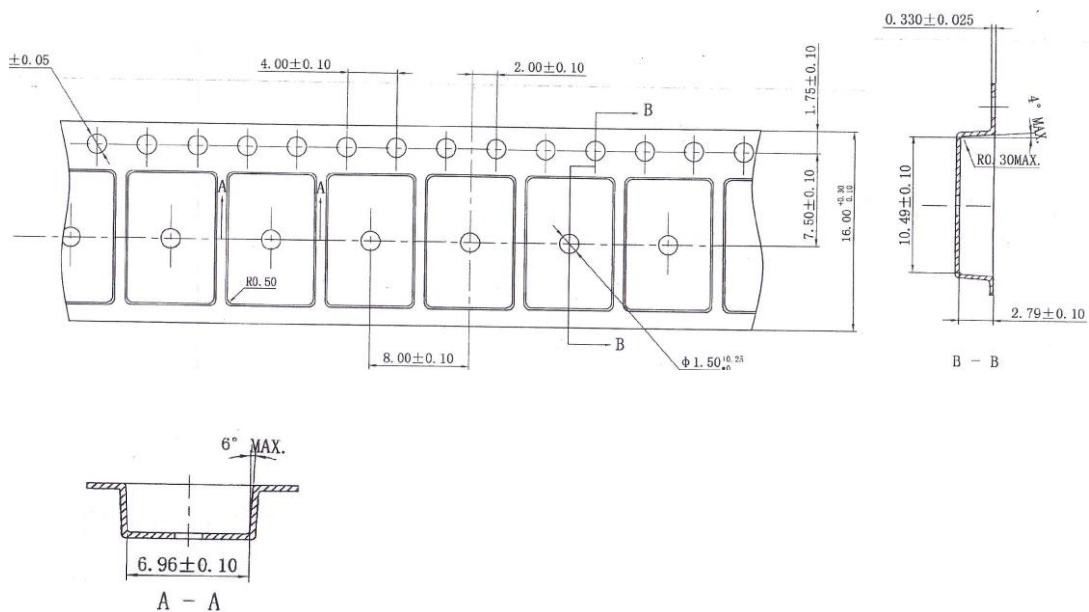



## TO-262

单位 Unit: mm

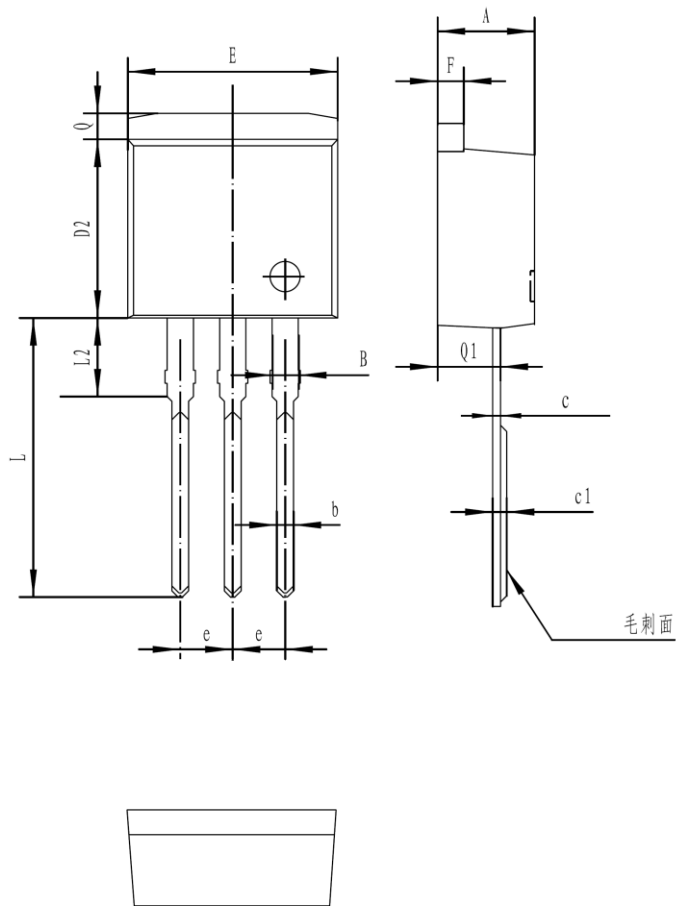

符号 symbol	MIN	MAX
A	4.40	4.90
B	1.10	1.40
b	0.70	0.95
c	0.30	0.60
c1	0.33	0.63
D2	8.20	9.20
E	9.60	10.50
e	2.39	2.69
F	1.20	1.35
L	13.11	14.61
L2	3.55	4.05
Q	1.10	1.40
Q1	2.65	2.85



## 外形尺寸 PACKAGE MECHANICAL DATA

TO-263

单位 Unit: mm

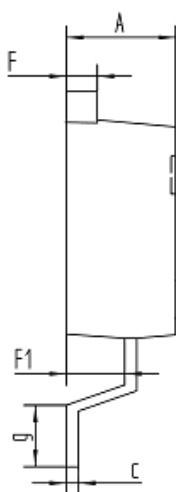
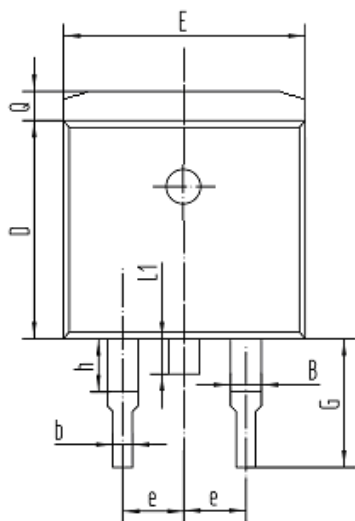

符合 symbol	MIN	MAX
A	4.3	4.8
B	1.2	1.4
D	8.5	8.8
E	9.5	10.5
F	1.2	1.4
F1	2.5	2.9
G	4.7	5.5
L1	1.4	1.7
Q	1.2	1.5
b	0.75	0.95
c	0.35	0.5
e	2.49	2.59
g	1.9	2.7
h	2.3	3.3

## 编带 REEL

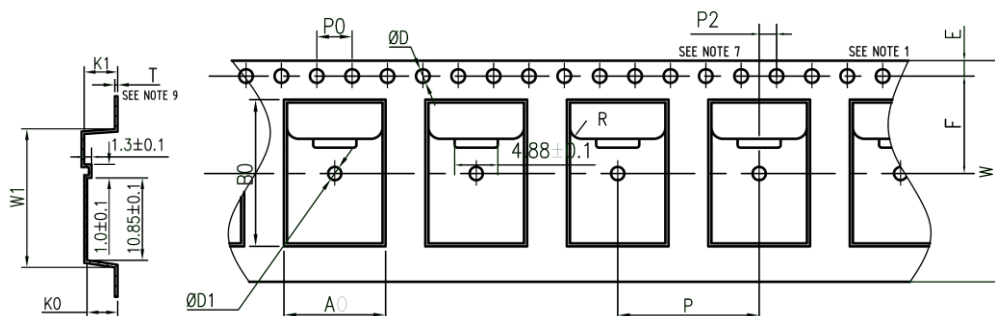

## NOTES

- 10 SPROCKET HOLE PITCH CUMULATIVE TOLERANCE 0.2mm;  
任意10个传输孔间距累积误差0.2mm;
- MATERIAL: BLACK CONDUCTIVE POLYSTYRENE;  
材料: 黑色防静电聚苯乙烯;
- DEMONSTRATIONS ARE IN mm (UNLESS OTHERWISE SPECIFIED);  
除非特别标注, 尺寸单位为毫米;
- K0 MEASURED FROM A PLANE ON THE INSIDE BOTTOM OF THE POCKET TO THE TOP SURFACE ON THE CARRIER;  
K0是从凹槽底部上表面到载带顶面的测量尺寸;
- A0 AND B0 MEASURED ON A PLANE 0.30mm ABOVE THE BOTTOM OF THE POCKET;  
从凹槽底部上方测量A0和B0的平面度是0.30mm;
- SURFACE RESISTIVITY IS BETWEEN  $1 \times 10^6$  TO  $1 \times 10^{10}$  OHMS/SQUARE;  
表面电阻 $1 \times 10^6 \sim 1 \times 10^{10} \Omega/\square$ ;
- Allowable Camber to be 1 mm/100 mm  
载带100mm以内, 弯曲度不可超过1mm。

外观	尺寸	外观	尺寸
P0	$4.0 \pm 0.1$	W	$24.0 \pm 0.3$
P2	$2.0 \pm 0.1$	A0	$10.8 \pm 0.2$
P	$16.0 \pm 0.1$	E	$1.75 \pm 0.1$
T	$0.35 \pm 0.05$	F	$11.5 \pm 0.1$
K0	$4.85 \pm 0.1$	D	$1.55 \pm 0.05$
B0	$16.3 \pm 0.1$	D1	$1.5 \pm 0.1$
		W1	规格1 $16.9 \pm 0.1$
			规格2 $17.2 \pm 0.1$



TO-220C

单位 Unit: mm

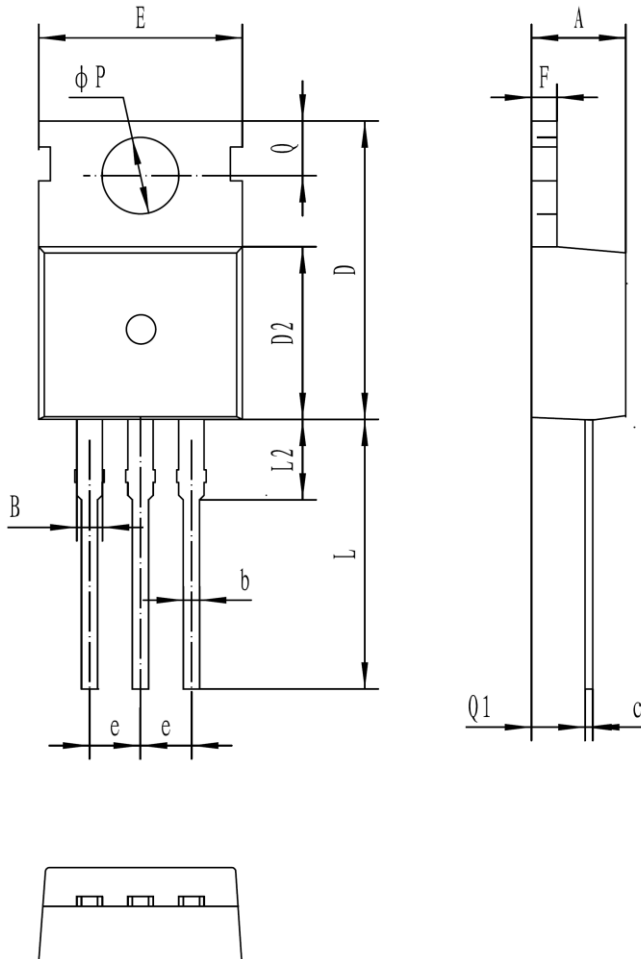

符号 symbol	MIN	MAX
A	4.30	4.70
B	1.10	1.40
b	0.70	0.95
c	0.40	0.65
D	15.20	16.20
D2	9.00	9.40
E	9.70	10.10
e	2.39	2.69
F	1.25	1.40
L	12.60	13.60
L2	2.80	3.20
Q	2.60	3.00
Q1	2.20	2.60
P	3.50	3.80







TO-220MF

单位 Unit: mm

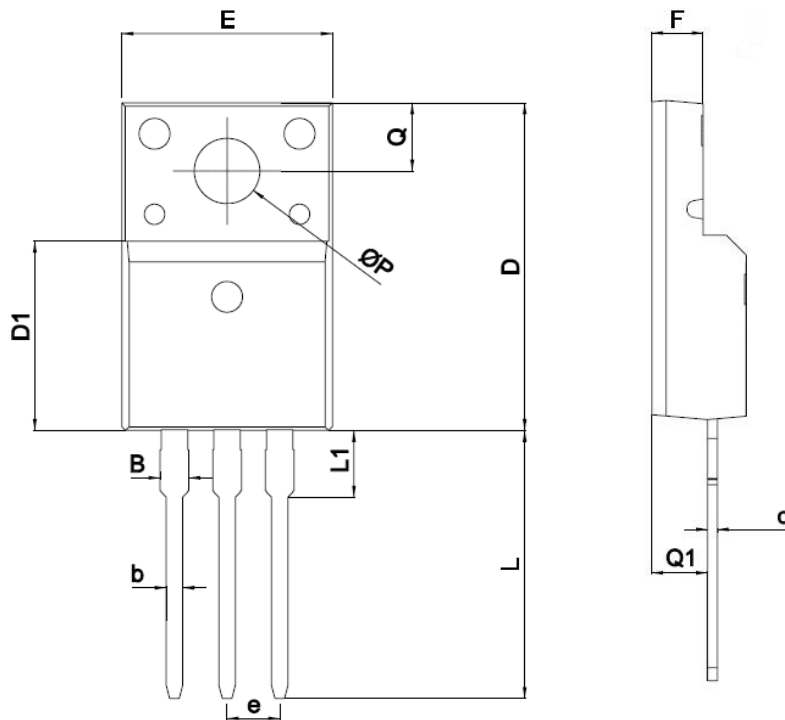

SYMBOL	mm	
	MIN	MAX
A	4.5	4.9
B		1.47
b	0.7	0.9
c	0.45	0.60
D	15.67	16.07
D1	9.04	9.20
e	2.54TYPE	
E	9.96	10.36
F	2.34	2.74
L	12.58	13.38
L1	3.13	3.33
Q	3.2	3.4
Q1	2.56	2.96
$\Phi P$	3.08	3.28





## TO-220MF-K1

单位 Unit: mm

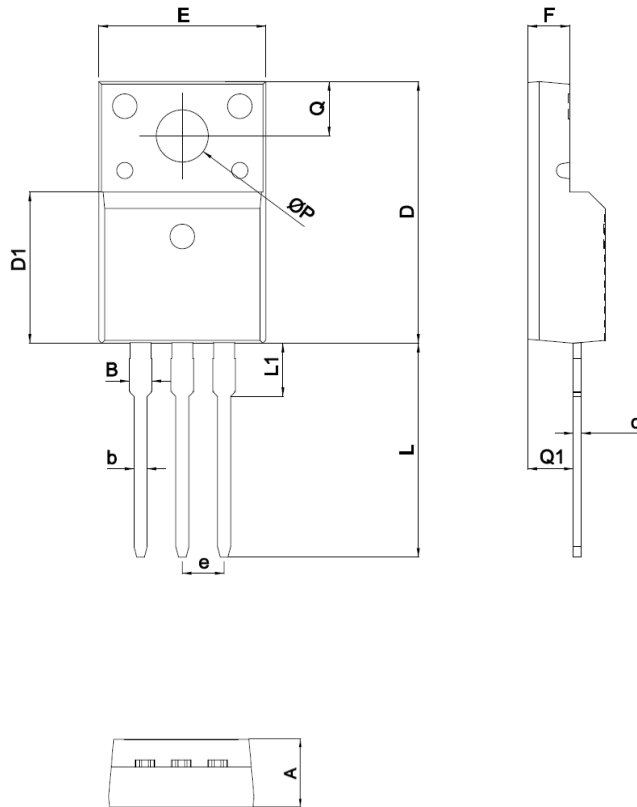

SYMBOL	mm	
	MIN	MAX
A	4.5	4.9
B	1.22	1.47
b	0.7	0.9
c	0.45	0.60
D	15.6	16.1
D1	9.0	9.3
e	2.54TYPE	
E	9.9	10.4
F	2.3	2.8
L	12.6	13.3
L1	3.1	3.4
Q	3.2	3.4
Q1	2.6	2.9
ΦP	3.0	3.5





TO-220MF-K2

单位 Unit: mm

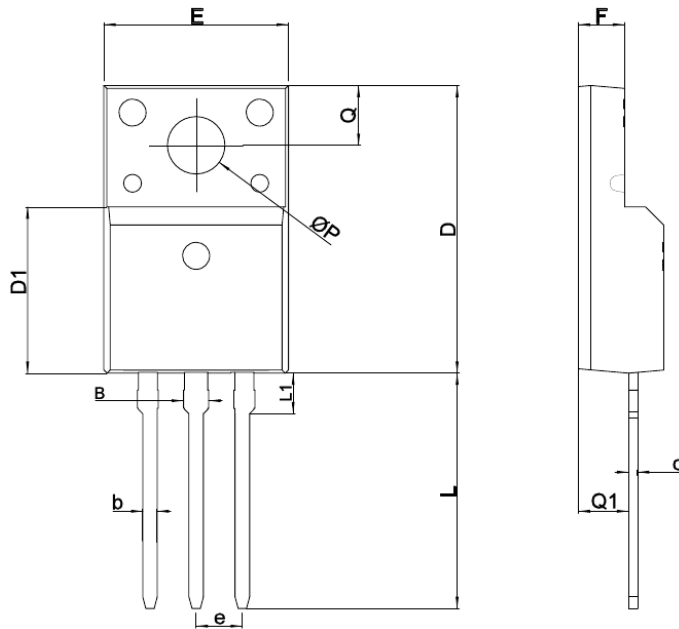

SYMBOL	mm	
	MIN	MAX
A	4.5	4.9
B		1.27
b	0.59	0.79
c	0.45	0.60
D	15.67	16.07
D1	8.97	9.37
e	2.54TYPE	
E	9.96	10.36
F	2.34	2.74
L	12.65	13.35
L1	1.80	2.20
Q	3.2	3.4
Q1	2.56	2.96
$\Phi P$	3.08	3.28





## 注意事项

1. 吉林华微电子股份有限公司的产品销售分为直销和销售代理，无论哪种方式，订货时请与公司核实。
2. 购买时请认清公司商标，如有疑问请与公司本部联系。
3. 在电路设计时请不要超过器件的绝对最大额定值，否则会影响整机的可靠性。
4. 本说明书如有版本变更不另外告知。

## NOTE

1. Jilin Sino-microelectronics co., Ltd sales its product either through direct sales or sales agent , thus, for customers, when ordering , please check with our company.
2. We strongly recommend customers check carefully on the trademark when buying our product, if there is any question, please don't be hesitate to contact us.
3. Please do not exceed the absolute maximum ratings of the device when circuit designing.
4. Jilin Sino-microelectronics co., Ltd reserves the right to make changes in this. specification sheet and is subject to change without prior notice.

## 联系方式

### 吉林华微电子股份有限公司

公司地址：吉林省吉林市深圳街 99 号

邮编：132013

总机：86-432-64678411

传真：86-432-64665812

网址：[www.hwdz.com.cn](http://www.hwdz.com.cn)

## CONTACT

### JILIN SINO-MICROELECTRONICS CO., LTD.

ADD: No.99 Shenzhen Street, Jilin City, Jilin Province, China.

Post Code: 132013

Tel: 86-432-64678411

Fax: 86-432-64665812

Web Site: [www.hwdz.com.cn](http://www.hwdz.com.cn)

